

NCPA Downlink

The Official Journal of the Northern California Packet Association
Serving Amateur Radio Digital Communication in Northern California

Summer, 1990

Issue number 3

Price \$3.50

The Mail Must Go Through...

A look at the BBS message forwarding network

Larry Kenney, WB9LOZ
NCPA Education Coordinator

There are now close to forty full-service packet bulletin board systems in Northern California, a similar number in the southern part of the state, and thousands more across the country

and around the world. You can enter a message on any one of these BBSs and, if it's addressed correctly, have it delivered to any of the other systems worldwide. Here in Northern California, more than a thousand personal messages, bulletins and NTS messages are entered into the packet network every day. More than two-thirds of this traffic is of a personal nature, messages going from one ham to another. Bulletins account for about a quarter of the messages, with the remaining five to ten percent being made up of messages from the National Traffic System.

Have you ever wondered how all of these messages get delivered? How does a message entered in California get sent to a BBS in New York? What determines the routing that's used for delivery of a message from San Francisco to a BBS in Los Angeles? How do bulletins get distributed? This article will answer those questions and a lot more as we give you an in-depth look into the BBS forwarding network.

The BBS Forwarding Network

When I first got on the air with packet in 1985, there were only about a dozen BBSs in the state. I can remember W6CUS, N6IIU, AA4RE and WA6NWE as being the first BBSs in this area. Messages were sent from one BBS to the other on the same frequencies used by the users, in most cases on 2 meters, often going through several digipeaters along the way. Twenty five messages in one day was about the average back then. As more and more hams got involved with packet radio and the number of

BBSs increased to accommodate them, the amount of traffic quickly increased. There soon was a need for a separate network to tie all of the BBSs together and to free up the user frequencies.

The Northern California bulletin board system operators (sysops) met on a quarterly basis to discuss mutual interests, system developments, problems, and so on. In the fall of 1986 the group was authorized the use of 223.58 Mhz as a "BBS forwarding frequency" and by the end of the year most of the systems had established a second port on that frequency. This greatly reduced the congestion, traffic moved more quickly between systems, and all seemed to be in fine shape. This situation didn't last for long, though. Soon 223.58 was congested and there was a need for more frequencies. NETROM was then available, so nodes were installed to help move traffic easier, but there was still the need for more spectrum.

Working with the Northern Amateur Relay Council of California (NARCC), the repeater coordinating group, packet users were authorized five more frequencies in the 220 MHz band, and that was the beginning of today's packet network. The present scheme for organizing the BBSs into a network was developed: Northern California was divided into several smaller areas with the BBSs in each of these areas able to send traffic to one another on a single frequency. Each of these groups was called a Local Area Network (LAN). Each BBS could pass messages outside of its LAN by using the

Continued on page 3

In This Issue

The Mail Must Go Through	1
Editorial	2
Dayton 1990	5
DXPSN Corner	5
Emergency BBS for Tactical EOC-to-EOC Packet Traffic	6
Building a "Real" Network	8
HF Packet of The Future	9
Pacsat Protocol Suite — An Overview	10
Walking Mobile Packet Radio Station Around The Earth	12
9600 Baud Packet Meeting Minutes	13
NCPA (NCXPN) H&W Traffic Committee	14
What Was the Question?	15
SAREX, 144.95, DXPSN, BBSs, and Keyboarding	17
NCPA Board Meeting Minutes	18
Sending International NTS Messages	19
Where to Find a BBS	19
The Band Plan	19

Editorial

Mike Chepponis K3MC

Welcome again, folks!

All of us on the staff of the Downlink hope you all appreciated our efforts for the Spring 1990 edition. We had fun putting it together, and hope that you had fun reading! Maybe even some of the information was useful? We trust that this Summer 1990 edition will suit your fancy, too!

For this issue, we continue with our tradition of high-quality journalism. We've got our usual excellent article by Larry, WB9LOZ, a super article by Weo Moerner, WN6I, on Emergency BBS for EOCs, an overview article by Fred Moore, KG6HQ, about his high tech global walk, a Dayton report by one of our very own members of the BoD of NCPA, and a whole lot more!

This is all very surprising and refreshing! So much is happening compared with other parts of the world in packet operation here! We are fortunate to have such a large talent pool of people here in Northern California who are willing to share pieces of their experience with us.

What is perhaps even more amazing is that this newsletter was assembled in record time! You see, our Board of Directors said that we should produce the Summer issue of the Downlink at warp speed to get the quarterly back on a reasonable schedule. So, those of us on the editorial staff really had to scramble to get this one together! Sometimes, tight deadlines bring out the best in people!

If you are new to NCPA and perhaps are seeing our newsletter for the first time, won't you consider joining us? There is a membership application stapled to the middle of this newsletter, and yearly dues are only \$10. When you join NCPA, you will receive all of the newsletters we have published so far that membership year, and you'll become a member of the largest, growing organization of digital users in Northern California! Your participation in NCPA ensures a vital future for packet in our area!

Our newsletter schedule is quarterly, once per season. We intend to stuff your mailbox with a fresh copy of the Downlink on or about January 1st, April 1st, July 1st, and October 1st. The deadlines for article submission are one month before the delivery dates, above. Since we are a quarterly, what we publish will tend to be high-quality, first run material that is not of a "bulletin" nature. Everything will have some connection to packet or to other digital modes or things concerning digital communications.

But you be the judge! Please, we appreciate your feedback! And, we appreciate your articles even more! Any comments of any kind that you might have on this newsletter can be directed at me via the BBS network to K3MC @ K3MC.#NOCAL.CA.USA.NA - and this is a pretty painless way to contact me and to get your ideas known! It is also the best way to submit your article for consideration for publication.

And, lastly, this issue marks the halfway point for your editor. Yes, I volunteered to do this because I believe that a vibrant newsletter is required for a vibrant NCPA! With only two issues left to my commitment, I am eagerly seeking others who want to "learn the ropes" and have some fun making the NCPA Downlink happen!

Vy 73! -Mike Chepponis, K3MC

The NCPA Downlink

Editor:

Mike Chepponis, K3MC
BBS: K3MC@K3MC.#NOCAL.CA.USA.NA
TCP/IP: mike@k3mc.ampr.org
Internet: k3mc@apple.com
or: mac@leg.ai.mit.edu
UUCP: ...!apple!k3mc
AppleLink: chepponis
CompuServe: 72117,2732
Prodigy: XNDN55A
US Mail: 211 Kansas Way, Fremont CA 94539

Layout/Typesetting:

Eric Williams, WD6CMU
BBS: WD6CMU@WD6CMU.#NOCAL.CA.USA.NA
CompuServe: 71336,1424

Publisher/Mailing:

Glenn Tenney, AA6ER
BBS: AA6ER@K3MC.#NOCAL.CA.USA.NA
Internet: tenny@well.sf.ca.us

Staff:

Patrick Mulrooney, N6QMY
BBS: N6QMY@N6QMY.#NOCAL.CA.USA.NA
Internet: pat@ubvax.ub.com

Steve Harding, KA6ETB
BBS: KA6ETB@N6LDL.#NOCAL.CA.USA.NA
Internet: steveh@atheron.com

Larry Kenney, WB9LOZ
BBS: WB9LOZ@W6PW.#NOCAL.CA.USA.NA

The NCPA Downlink is published quarterly by the Northern California Packet Association, 6680B Alhambra Ave. Suite 111, Martinez, CA 94553, for the entertainment and education of amateur Radio operators using digital modes, and those with an interest in them. A one-year membership in the NCPA, including a subscription to the Downlink, is \$10.00 per year in the U.S. and its possessions.

All original material not attributed to another source is Copyright © 1990 by NCPA. Excerpts may be drawn from this publication without prior permission provided the original contributor is credited and this publication is cited as the source.

The Mail Must Go Through...

Continued from page 1

220 "backbone frequency," one that tied all of the LANs together via adjacent nodes; this network was called the Wide Area Network (WAN). Although there have been several changes and refinements over the past few years, this network is the one still in use today.

We now have six LANS: Sacramento Valley (SACVAL) which covers the area from Dixon and Sacramento north to Redding, East Bay (EBAY) covering Contra Costa County, the Sierras and the central valley, North Bay (NBAY) for BBSs in San Francisco, Richmond and Berkeley south to Fremont and Palo Alto, South Bay (SBAY) serving the Silicon Valley area, Monterey Bay (MRYBAY) for the systems on the south and west side of the Santa Cruz Mountains, and one that has never had a name and has always been called "the other LAN," centered south and east of San Jose.

When the network was first established, all of the systems in the network would send messages to each other. If the AA4RE BBS in Gilroy had a message for someone at the WD6CMU BBS in Richmond, it would connect direct to WD6CMU via the 220 backbone frequency and send it. At the same time, if the K6RAU BBS in Merced had a message for a user of the W6PW BBS in San Francisco, it would connect direct and

send it. As the volume of traffic increased, the number of BBSs using the backbone frequency at the same time increased and we once again faced a great deal of congestion.

To limit the number of BBSs using the backbone, the "Gateway" concept was put into use. Each LAN now has a "Gateway BBS." The six gateway BBSs are: SACVAL-WA6RDH, EBAY-KA6FUB, NBAY-W6PW, SBAY-W8GEC, MRYPAY-N6IYA, and "OTHER"-AA4RE. Messages for other LANs or for BBSs outside of California are sent first to the LAN gateway BBS. The gateway then uses the backbone to send the messages to the other gateways which will then send them to appropriate system within their LAN. Let's look at some specific examples. First, let's say a user of the W6FGC BBS in Twain Harte enters a message for a user of the N6QMY BBS in Fremont. W6FGC would send the message to KA6FUB, the EBAY LAN gateway, KA6FUB then sends it to W6PW, the NBAY LAN gateway, and W6PW would send the message to N6QMY. Now another example: A KB6IRS user in Soquel enters a message for someone who uses WA6NWE in Sacramento. KB6IRS would send the message to N6IYA, the MRYBAY gateway, then N6IYA would

send it to WA6RDH, the SACVAL gateway, which would send it to WA6NWE. With only 6 LAN gateways using the backbone frequency, the congestion is limited, allowing traffic to move more quickly from LAN to LAN.

Getting Your Message to the Right Place

As I mentioned at the beginning of this article, a message can be entered on any BBS for any other full-service BBS in the world. (Personal BBSs and TNC mailboxes are excluded.) You can enter a message for someone who uses a BBS in New York just about as easily as you enter a message for someone who uses the same BBS as you do. You have to make sure that you address the message correctly, though, indicating the call sign of the other BBS and the two letter state abbreviation. Let's say we want to send a personal message to Bob, NG2P, who uses the WB2WXQ BBS in Rochester, New York. At the prompt we would enter: SP NG2P @ WB2WXQ.NY separating the BBS call and the state abbreviation with a period. It's as simple as that!

NTS messages use a special addressing format: ST zipcode @ NTSxx where the xx is the state abbreviation. An example would be ST 61644 @ NTSIL for a message going to Peoria, Illinois. Note the use of ST for NTS messages, rather

Continued on page 4

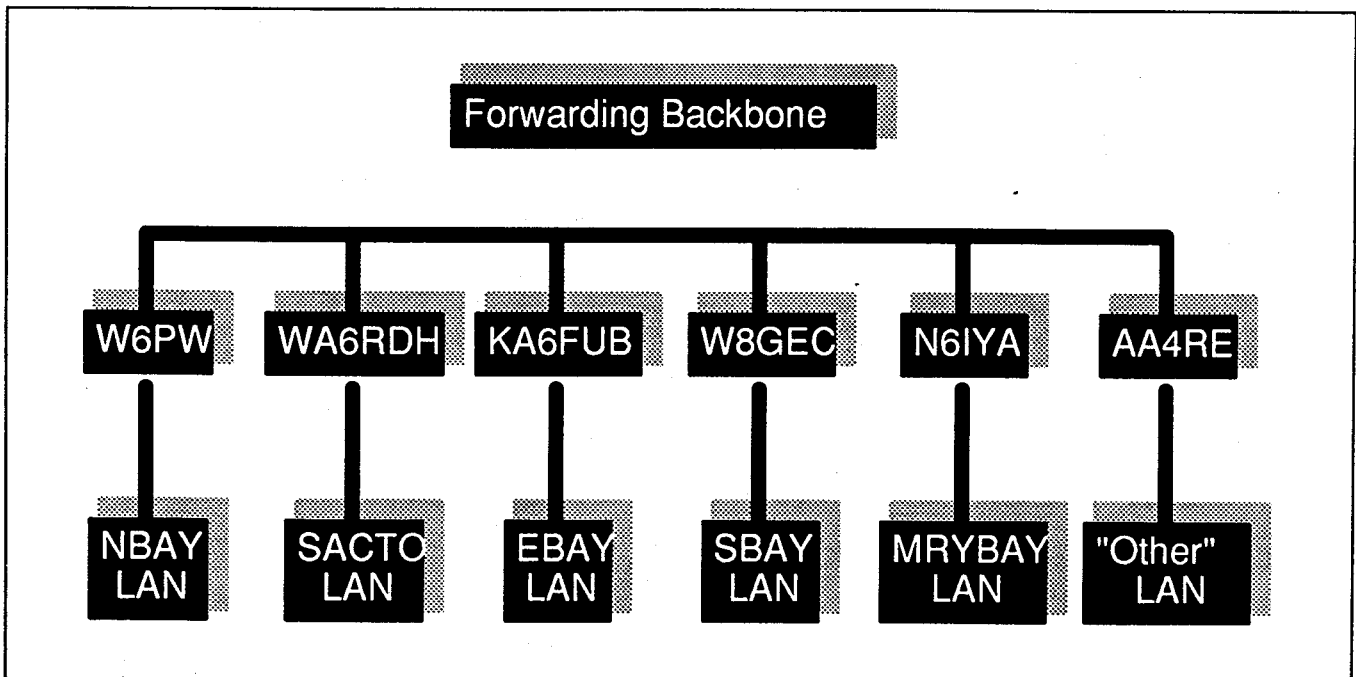

The Mail Must Go Through...

Continued from page 3

than SP, which is used for personal messages, or SB, which is used for bulletins.

How does your BBS know how or where to send that message to NG2P or that NTS message to Peoria? Each BBS has a forward file that's used for this purpose. The forward file contains individual sections for each station the BBS connects to, indicating the connecting path, the times to connect, and the callsigns or designators of the messages to be sent. This file is set up by the sysop for his particular BBS, and he has to make sure that the listing is correct or messages will be sent to the wrong BBS.

Since I'm the sysop of W6PW, I'll use the W6PW forward file as an example here. I have a section for each BBS in the NBAY LAN and a section for each of the other five gateway BBSs. Most of the sections are short, containing only the call of the BBS, appropriate zip codes for forwarding NTS messages and possibly a few special designators. A few of the sections are quite lengthy, however. W6PW forwards most messages leaving California to N6IYA, since he has a port on the 20 meter HF net. The N6IYA section in the W6PW forward file contains the BBS calls of all MRYBAY systems, every appropriate state abbreviation, all non-California NTS designators, and the country and continent codes used for sending messages outside of the US.

In the past, the forward file contained all of the BBS callsigns in the US, but it got to the point where it was impossible to keep the list up to date, so the use of the state and country abbreviations was introduced. Now the forward file has only the callsigns of California BBSs, state and country abbreviations and NTS and bulletin designators. The message to NG2P would be sent to N6IYA based on the "NY" in the address, not the BBS call. When it arrived in New York, the BBS call would then be used for the remainder of its trip. The NTS message for Peoria, Illinois, would be forwarded using the "NTSIL" address.

The KA6FUB and AA4RE sections of the W6PW forward file contain the callsigns of all the Southern California BBSs, since messages for the southern

part of the state are handled by either one of those gateways. KA6FUB uses a route down the central valley, while AA4RE uses a coastal route. Messages for Southern California from NBAY LAN users might be sent via either route; which one depends solely on which BBS W6PW happens to connect to first.

Each BBS begins a forwarding cycle once every hour. It first does a comparison of all messages on the system with the calls, abbreviations and designators in the forward file. When it finds a match, it uses the information given in the file to connect to the appropriate station and then sends the message. All messages for a particular BBS are forwarded before it moves on to the next BBS. In addition, before disconnecting, there is a check to see if there are any messages to be sent back to the BBS originating the connection. This is called reverse forwarding.

Bulletin Distribution

Finally, we need to look at how bulletins are sent to everyone. There are several designators used for bulletin distribution: ALLCAN - Send to all BBSs in Northern California, ALLCAS - Send to all BBSs in Southern California, ALLCA - Send to all BBSs in the entire state of California, ALLUSW - Send to all BBSs in the western United States, USA - Send to all BBSs in the country, plus special local designators. For each designator, there is an associated distribution list of BBS callsigns. When a message is received with one of these designators on it, a special line is added to the message listing showing the calls from the distribution list. That line is then scanned for comparison to the forward file during the forwarding period. As before, when a match is found, the bulletin is forwarded. This method allows the same message to be sent to many different stations automatically.

To prevent duplication of bulletins, each one is assigned a unique bulletin identification (BID) when it's first entered. When a bulletin is to be forwarded, the receiving BBS is first sent the message's BID. The BBS checks to see whether or not it has the message and then returns either "OK" (send it, I don't

have it) or "NO" (I have it already). This method of distribution prevents breakdowns in the forwarding chain if one or more of the BBSs are off-line. Here in Northern California each of the LAN gateways forwards bulletins to the other gateways and each BBS within a LAN forwards bulletins to all others in the LAN, so there is plenty of duplication.

Many bulletins, such as those from the ARRL or AMSAT, are assigned a BID by the originating agency. By assigning these bulletins a unique BID, only one copy is received by each BBS, even though the bulletin may have been copied from computer phone networks or RTTY broadcasts, etc., and entered into the packet network at several points. Normally generated automatically by the BBS at which the bulletin is originated, the BID in these cases can be entered with a variation of the send command, as in: SB ARRL @ ARL \$ARLB0512

Messages going to other states, except for the states right near the California boarder, are sent to the BBSs with HF ports. We have seven HF stations at the present time: 40 meters: W6CUS; 30 meters: N6EEG; 20 meters: N6IYA - beamed east, N6MPW - beamed toward the Pacific Net, and KB6GOZ; 15 meters: N6OA; 10 meters: WW6L. Each gateway sysop has to determine which HF station to use for the messages leaving his LAN. Depending on the state or country of destination, the time of the year and band conditions, the choice of HF station can vary quite frequently. The HF sysops will often advise the rest of us as to what areas they are able to work to help us in making the correct decision.

There have been continual changes to the network as it's expanded to meet the needs of the day, and there have been changes in the methods used for forwarding the traffic. The use of packet continues to grow, so we can expect further changes in the months ahead. Rather than more frequencies, more BBSs and more nodes, the future changes will be based on new transmission methods, increased data speeds, compressed messages, and other means of increasing the quantity of data being sent from one system to another. Watch for announcements of these changes in the months ahead.

EOT

Dayton 1990, or, Here We Go Again.

Mike Bothe, KB6OWT
Linda Rae Sande, N6QYU

If I could use only one word to describe the 1990 Dayton Ham-Vention it would have to be "stale". While attendance was about the same as last year and the usual exhibitors were present, nothing struck me as being really exciting.

The impression that I got from some of the other exhibitors was even one of "ho hum". Heathkit was at the Dallas HamCon last year with a booth that took a day to setup and was very impressive, but at Dayton with only a few simple tables.

I had hoped to see ICOM's new receivers, the R 1 and R 100, but was told that production problems would delay release for some time.

AEA had a new HF antenna, the Iso Loop, that is a boon to those of us that need to operate a clandestine HF station from our condo's or other areas with restrictive zoning laws.

In talking with several other Amateurs afterwards, I got the same impression -

"where was that one thing that you just couldn't leave without?"... it just wasn't there. (Those who were on the lookout for commercial pagers or radios had much better luck than us Amateurs in this respect.)

One thing I did notice was that one or two of the junque dealers that normally reside in the flea market area migrated inside to the main show floor. These are the purveyors of the dreaded dancing flower, the golf umbrella, and other such junque that doesn't belong at a ham show!

As usual, DARA did a super job of staging the HamVention. There were ample things for non-ham spouses to do while the other half drooled over the acres of superlative values in the flea market. Also, buses were used to transport the throngs of attendees from hotels to the Hara Arena and back. What a novel approach to traffic management—no traffic jams in the parking lot.

A full schedule of forums were once again on tap. They ranged in subject from FCC and legal topics to the usual

"How to" seminars. AMSAT is gaining in popularity and it's evident at Dayton.

Saturday evening gave us a good excuse to get away from northern Dayton and into the downtown convention center for the banquet and awards ceremony. There isn't a better filet mignon that side of the Mississippi, and Ronnie Milsap was an entertaining speaker.

When it's all over and the booths have been torn down, the Hara Arena looks like an abandoned warehouse and the parking lot looks like the aftermath of a major tornado. But the Bombay Bicycle Club is open for a great dinner and a chance to relax. And if you're stuck in Dayton for an additional day due to airline restrictions, check out the Air Force Museum. It was the second time for us and even more enlightening with the addition of their SR-71 (a retired spy plane that was parked in the middle of an adjoining field). By the time you board your own plane to head home, your feet have declared themselves AWOL and your wallet is empty. Oh well—you have a year to recover!

EOT

DXPSN Corner

Tom Wood N6IXX

Hi, my name is Tom Wood, N6IXX. I'm the "Network Coordinator" for the DX Packet Spotting Network. I operate a DXPSN node on 145.770 in Walnut Creek.

This is the first in what I hope will be several articles concerning the DXPSN, and what is going on there. This article will be of a general nature, with subsequent articles covering specific activities on the DXPSN.

The DXPSN is a multiuser system. We recently set a new user record of 145 connects at the same time. These connects were spread over the 12 existing nodes state wide.

If you have not checked into the DXPSN, we invite you to do so. You might not be a "DX type," but I think you will find the technology interesting nonetheless. While we are still working on implementing a method for external mail

forwarding, our internal mail system works quite nicely.

See the box below for the node nearest you. When you connect to one of these nodes, "H" will get you a list of the most frequently used commands. Give it a try!

With the release PacketCluster 4-3, things have really become reliable, and as a result, much less demanding on the SYSOPS.

Along with the improved software, we have received assistance from WA8DED. Ron Raikes has given us invaluable advice on what parameter settings are best suited to a network like ours.

These parameters are quite different from those found as defaults on TNC's.

WA8DED's assistance and advice will be the subject of my next article.

EOT

N6IXX	Walnut Creek	145.770
K6LLK	Mountain View	144.950
W6GO	Rio Linda	144.950
W6OAT	Redwood City	145.770
KN6J	Santa Cruz Mountains	146.580
WB2CHO	Santa Rosa	144.950
KI3V	Reno	144.950
KD6AZ	Tracy	No VHF
K6PBT-6	Stockton	No VHF
W6LEH	Modesto	146.580
K6XJ	Clovis/Fresno	144.950
WA6IET	Santa Maria	144.950

Emergency BBS for Tactical EOC-to-EOC Packet Traffic

W. E. Moerner WN6I

Tactical traffic between Emergency Operations Centers (EOCs) often consists of short messages requesting or providing status updates. As is usual, the use of packet radio can provide a modicum of security for such messages while also freeing up voice channels for other uses. For the purposes of this document, "EOC" should be regarded in the broad sense to signify major emergency operations locations, such as city EOCs, County Communications, Red Cross chapter headquarters, etc. This document describes a packet radio scheme for handling EOC-EOC tactical traffic in a widespread emergency that was discussed during the Santa Clara County EC Council meeting on March 1, 1990.

...it appears easiest to rely on a system that uses BBS technology and terminology.

Although there are many ways in which packet radio could handle such message traffic (e.g., TCP/IP, BBS, keyboard to keyboard), the majority of hams who have used packet radio are already well-versed in BBS usage. In order to have an easily accessible system that requires minimal training, can be used on a variety of computers, and tolerates many different packet stations, it appears easiest to rely on a system that uses BBS technology and terminology. A further advantage of a BBS is its ability to automatically store the traffic that was passed; killed messages do not actually disappear until a sysop command is given and can remain as a log of the event.

The following assumption is made within Santa Clara County: each EOC will have a packet operator who knows how to connect to a BBS using AX.25 protocol. The EOC or operator may have more capabilities and training (computer, knowledge of TCP/IP, etc.), but in an emergency, it makes the most sense to configure a system that requires only minimal skill and equipment. The simpler the system is, the more likely it is that it will be functional in an area-wide disaster.

One method of passing traffic between EOCs might be to ask each EOC to connect directly to each of the other EOCs. This type of multi-connected, keyboard to keyboard network is impractical to use in an emergency as a good path must be established between all pairs of locations. A much more realistic network is a star-shaped topology with a central BBS at a moderately high location to which all of the EOCs connect to send and receive traffic. In this configuration, each EOC need only provide a good path to the central BBS.

It is essential for the central emergency-oriented BBS to be separate from the normal BBS network.

It is essential for the central emergency-oriented BBS to be separate from the normal BBS network. In a disaster, the stations using the emergency BBS must not be distracted by such things as "for sale" messages, general QSTs, and health and welfare traffic; these services are already handled well by the standard BBS network.

A further requirement for the central emergency-oriented BBS is that it have multiple connect capabilities. Many EOCs need to pass traffic and must be able to connect at the same time rather than wait for the BBS to be free. The exact maximum number of active stations on one frequency is limited by the 1200 baud data rate of many current TNCs which implies about 4-6 stations on the same frequency. In order to handle 10 or more EOCs, multiple ports are also required.

A final requirement for the central emergency BBS is automatic emergency power as power failure is likely during a widespread event.

In the event that the coverage area is extensive or the number of EOCs is large enough to overload one computer, two or more emergency BBSes can be established which are linked by a backbone frequency in a small network. This scheme also provides back up capabilities in case one of the BBSes malfunctions. For example, in Santa Clara County, it may be useful to establish a northern BBS and a southern BBS and to connect the two in a backbone.

Our emergency BBS system is currently composed of the following elements:

1. A multi-connect BBS at a central high level location in the county on emergency power. We have selected at this time the "BB" mailbox program by AA4RE because it provides many connections on each of several ports.

2. Packet stations at the various EOCs (including County Comm and other major locations such as Red Cross Chapters).

During the emergency, the EOC stations all connect to the BBS as required. The EOC stations can send messages to other EOCs, receive messages addressed to them, and then disconnect until they again need to send or receive traffic. We have defined a particular convention for setting callsigns and beacon text which makes traffic passing very convenient. The convention we use for sending and receiving messages is described at the end of this document. In essence, the stations set the AX.25 callsign (i.e.,

BBS callsign:	WN6I-6
Frequency:	223.56 MHz and 144.91 MHz
BBS program:	AA4RE BB version 2.8
Location:	IBM Almaden Research Center in San Jose at 1000 feet, with automatic emergency power and automatic restart

MYCALL) to the tactical ID, and the amateur station callsign is placed in the beacon text with a 10 minute beacon interval. In the near future the BB software will be enhanced to implement tactical ID's in a more elegant manner; in this sense, the scheme described here is only a temporary stopgap measure.

In the case that an EOC has a personal mailbox running in their TNC, the central BBS can be configured to automatically forward mail to this TNC. This means that the EOC need only connect to the central BBS when sending traffic; it is

not necessary to connect to see if there is any pending traffic to be received.

To test these concepts and to have a system on the air immediately in case the next earthquake occurs tomorrow, we have set up such an emergency BBS system for testing and immediate use if a disaster occurs. This system uses donated personal equipment and a site provided by the IBM Amateur Radio Club.

We encourage EOC packet operators to connect to this BBS to determine if a good path exists. This will help us to determine if a second BBS is required

and where it should be located. If required, you may choose to use one of the digipeaters on 223.56 such as NT6V-4 and N6IU-4, although it would be best to locate the emergency BBS(s) where no digipeating is required. Several digipeaters are also available on 144.91 MHz.

This system will evolve with time as we gain experience; however, it is most important to have at least a starting system on the air. As usual, comments and suggestions are welcome.

EOT

Emergency BBS Operation Rules

WN6I, N6KL, N6MWD

The following information provides the abbreviations to be used when sending messages from EOC to EOC via the BB Emergency BBS.

1. Each station has a short-tactical ID as shown in the list below. Set MYCALL to your tactical ID. For example, San Jose EOC would set MYCALL to SJEOC.

2. At the same time, to satisfy FCC regulations for station identification, the beacon should be set to a 10 minute interval, and put your amateur radio callsign in the message text. For example:

```
MYCALL SJEOC
BEACON every 60
BTEXT San Jose EOC station, AA6HX
```

NOTE: After the event is over, be sure to remember to restore MYCALL to your FCC-issued callsign AND be sure to type "BEACON EVERY 0" to turn off beacon generation!

3. Even though the emergency BBS allows many stations to be connected at the same time, stay connected only as long as necessary to get your mail and/or to send mail.

4. With these assumptions, you can send mail from one EOC to another by simply using the tactical callsign. For example:

```
s lgeoc (to send a message to Los Gatos)
```

CAMEOC	Campbell	LGEOC	Los Gatos	SCEOC	Santa Clara
CUPEOC	Cupertino	MILEOC	Milpitas	SAEOC	Saratoga
CNTYCOM	County EOC (at County Comm)	MHEOC	Morgan Hill	STAEOC	Stanford
GILEOC	Gilroy	MTVEOC	Mountain View	LGRC	Los Gatos Red Cross
LAEOC	Los Altos	PAEOC	Palo Alto	SUNEOC	Sunnyvale
LAHEOC	Los Altos Hills	PGE	Pacific Gas & Electric	SJRC	San Jose Red Cross
		SJEOC	San Jose	PARC	Palo Alto Red Cross

5. For the title of the message, use something descriptive about the person to whom the message is addressed. For example:

```
Msg for Mr. Joe Smith
```

6. As always, within the message, use good amateur practice by specifying:

```
To: Name and Position
From: Name and Position
Text
(Date and time are automatic.)
```

7. If you are SJEOC, see what messages have been sent to you by typing:

```
l> sjeoc
```

This will allow you to see what messages are "to" San Jose. Then read the message by typing:

```
r # (# is the actual message number)
```

Or, use the command "rm", which means "read mine."

8. To see if a message you sent has been read, look at the message status field. A "Y" means the message has been read by the recipient. You can delete messages sent to you or sent by you as required using "k #".

9. Here are the standard abbreviations to use:

Building a "Real" Network

Brian Lloyd, WB6RQN
124 Churchill Avenue
Palo Alto, CA 94301
wb6rqn@k3mc
brian@telebit.com

One item that I noticed upon getting on the air here in the South Bay area is that there simply is no real network that supports TCP/IP and the network that supports the other AX.25 users (BBS and DX Packet Cluster) is tenuous at best. It is my feeling that, if properly architected, the TCP/IP network and the BBS network (for want of a better word) can actually come together to form a common network.

Building the network backbone

The current practice of using simplex frequencies shared by more than two network backbone "neighbors" is very poor. AX.25 does not deal well at all with trying to share a frequency. The key to an effective backbone is to create reliable point-to-point links. In addition, full-duplex links are very desirable because they more than double the throughput (the improvement in throughput can be ten times or more in some cases). The network nodes should communicate point-to-point using cross-band full-duplex, e.g., node A transmits to node B on 70 cm while node B transmits to node A on 1.25 M. The result is that there is no link turnaround and ACKs can get back to the sender while it is sending thus keeping the flow of information going at full speed.

Full-duplex operation of the backbone links also produces another benefit: few or no retries. This, along with more available bandwidth, results in fewer delays and reduced memory requirement in the node or conversely the ability of a node to handle more traffic. The beauty of full-duplex operation is that it can be accomplished with minimal change to existing facilities.

The key to constructing full-duplex links involves having receivers and transmitters that can operate simultaneously. Most of our existing voice-grade radios are inherently half-duplex and can only serve a half a link. The transmitters are the hardest to come by but our existing radios will serve as the

required transmitters. Fortunately for us inexpensive outboard receivers that will cover a variety of frequencies and bands are readily available -- as VHF/UHF scanners. The major problem with scanner receivers is that their front-ends tend to be broad banded (by design) and they tend to have a somewhat high noise figure. Both of these problems can be cured by a combination preamplifier and helical resonator, such as the one sold by Hamtronics. This may not be needed at every link site so, as they say in the UK, just "suck it and see."

Full duplex operation will work with almost any type of node including TCP/IP gateways, NET/ROM nodes, and even TexNet nodes. The key is if the equipment can generate packets while it is receiving packets. If the TNC software does not provide an option to enable full duplex operation (FULLDUP ON) you can simply disconnect the carrier detect line from the modem to the comm chip. Now the node will transmit whenever it has data. As an additional mod you can set up the transmitter to remain key-down all the time eliminating all key-up delays (it might be prudent to add fans to the heat sinks). Most TNCs shut down the audio to the transmitter when they are not sending data. You will have to defeat this feature so that the transmitter generates HDLC Flag sequences when no data is being transmitted. The node should also generate an ID packet every 10 minutes regardless since the transmitter is always on the air.

Now what do we do with all this stuff when faster radios become available? We just drop the faster radios into the place of the slower radios and run them full duplex as well. The existing Heatherington (WA4DSY) 56 Kbps modems are designed to operate full duplex so they will work just fine in this environment. The proposed 250 Kbps Elmore/Rowett 33 cm radios are inherently half-duplex but there is nothing to stop someone from only populating half the board, either the receiver or the transmitter, so that full-duplex becomes possible.

Choosing the Networking Protocol

The foregoing discussion of full-duplex does not preclude any networking protocol currently in-use or proposed for amateur digital communications. Some implementations, however, offer more expansibility and upgradability. I personally would choose a proven, standard networking protocol such as IP over NET/ROM for backbone communications. The routing protocols for IP are more mature and IP can handle asymmetrical routing (asymmetrical routing is where the path from A to B may be different from the path from B to A thus allowing one-way links to exist in some areas). Also IP offers us the ability to use commercial networking components and to interoperate with existing networks -- a significant plus in times of emergency when all resources must be used.

But I suspect that many of you are now asking, "gee, that's great for the IPers but what about the guy with just a dumb terminal and a TNC? How does he or she participate?" The AX.25 users and the BBSs are supported by terminal servers in their local area networks. The terminal servers function in a manner very similar to an existing NET/ROM node in that you connect to the terminal server and then command the terminal server to connect you to someplace else in the network. The terminal server can even be programmed to connect a user to a host or BBS automatically. This makes things very simple for the user -- a real plus in times of emergency because they do not need to know a map of the network to send and receive messages.

Since the network backbone runs TCP/IP it is very easy to add multi-user UNIX systems to function as application servers. These application servers can be programmed to appear just like a standard WORLI or WA7MBL BBS so that the users will feel right at home. On the other hand the BBS mode can provide a command that allows the user to have access to the entire capability of a UNIX system, a feature that no ordinary BBS can ever hope to offer. The power of the

Continued on page 11

HF Packet of The Future

Raymond Petit W7GHM

In March of 1990, AX0X and W7GHM conducted a series of one-way tests of a new HF data communication system design over the 1500 mile path between Boulder, Colorado and Oak Harbor, Washington. On 5 different days, and on the 80, 40, 30, and 15 meter bands, Ed sent text from Isaiah 55 to Ray at higher speeds than any other data mode was able to deliver in the same band conditions, and Ed's "Cloverleaf" signal was so compact that twenty of them could have been packed, without mutual interference into the same 2 kHz space now used by one packet channel.

On 15 meters, Ray was printing data at 75 bits/sec free of errors. (The fastest HF packet transfer rate observed in a series of BBS file downloads under ideal band conditions was about 70 bits/sec.) On 30 and 40 Meters during a time when the packet link between AK0X and W7GHM was nothing but retries, Ray got 50 bits/second from the Clover link. The design limit of AMTOR is 33. On 80 meters, when it was necessary to repeat single letters several times on CW to be understood, the Clover link delivered 15 bits/second, free of errors.

Clover Beats The Multipath

During a series of tests just completed by Willard Shockey, N7JTQ and Raymond Petit, W7GHM, a one-way Clover link delivered throughput-per-bandwidth performance from about 50 to over 1000 times better than HF packet in the severe multipath environment of a nighttime 50-mile path on 80 meters.

The first test began at 10 pm on April 29. The Clover link transferred data at 37 bits/second on a sustained basis without losing or garbling any data. Willard and Ray were unable to establish a packet link because the TNC's retried out making connect requests.

The second test began at 9 pm on April 30. The Clover link delivered 75 bits/second with one in ten of the data blocks lost. (The two-way Clover protocol will provide for retransmission

of lost blocks without requiring retransmission of blocks already correctly received). Shortly after 10 pm an attempted file transfer on packet was aborted after a few minutes by a link failure. The average data rate was 0.7 bit/sec. A second attempt produced a nearly identical result. The Clover one-way link then delivered 117 blocks of data at 50 bits/sec, losing only two blocks.

On May 2 at 7 pm the third test was conducted. The conditions were much more stable, and a 2K file transfer on packet averaged about 31 bits/second. Afterwards the Clover link delivered 75 bits/sec. At about 8 pm another packet file transfer averaged about 17 bits/sec and it was followed by a Clover data transfer at 50 bits/sec.

The performance "figure of merit" was obtained by dividing the number of correctly-received bits per second by the spacing (in Hertz) required to guarantee that two signals of the same type do not cause mutual interference even if one is 60 dB stronger than the other. For a Clover signal, this spacing is 100 Hz. Packet and AMTOR require at least 20 times this space.

Ultra-narrow Bandwidth

For practical purposes a Clover signal is entirely contained in a channel only 100 Hz wide. A Clover signal in the neighbor channel will not cause interference even if it is 60 dB stronger than the signal to which the receiver is tuned. A network of 10 Clover links can be maintained without mutual interference in a 1 kHz band. Each channel is a "clear channel": no collisions, no "splatter", and no keyclicks come from the other users, even if they are much stronger.

Adaptive Two-way Protocol

A Clover link communicates data at the highest speed the RF propagation path permits. As the band conditions change the system adapts to them automatically. Under the best conditions it operates at above 100 correct data bits per second delivered to the user. Under

the worst conditions, conditions in which even CW data rates approach zero, a Clover link can communicate a few bits per second.

Corrects Errors

The Clover design uses Reed-Solomon error-control coding to correct errors in transmission, rather than rejecting a block of data on account of the errors. The coding is set such that it will recover blocks which have as many as 10% of their data symbols lost. If too many errors occur, the receiving station obtains a retransmission from the sender. It is never necessary to retransmit a block of data which has been received successfully on account of errors in previous blocks.

Easy Interface to Application

The data link is completely transparent to the data user. No restriction exists on the alphabets or data sequences. There are no illegal data codes. Input is accepted as a sequence of bytes and delivered to the output of the link in the same format. Programs using a Clover link are totally free to define their data in the ways best suited to their needs.

Frequency and Time Stable

The Clover modem requires and takes advantage of the extreme frequency precision and stability of its transceivers. It also requires accurate knowledge of time. The transceivers obtain both the frequency and time information automatically from observations of a primary frequency and time standard (WWV, for example). A Clover channel can be centered 50 Hz from a band edge with confidence.

A Gift to the Amateur Radio Community

Two Clover transceivers are under construction. When the system has been verified by extensive additional on-the-air testing, the complete specification for this new mode will be released to the public domain.

EOT

Pacsat Protocol Suite — An Overview

Harold Price NK6K
Jeff Ward G0IK8KA

The authors have been struggling with the question "How can we make the best use of a bandwidth-limited low earth orbiting digital store-and-forward system with a worldwide, unstructured, heterogeneous user base?" since December, 1984. In answer, we have proposed the use of a broadcast protocol as the basic downlink method, and a "file server" rather than a BBS application. This document provides a brief overview of these conclusions, the companion specification documents provide the implementation details.

A PACSAT, a generic term which encompasses both the University of Surrey's UO-14 and the AMSAT microsats AO-16 and LO-19, is a bandwidth limited device. The number of up and downlinks is much less than the number of users, and the capacity of the link is much less than the offered load. We feel that this is the critical design driver, and the access methods must be optimized with this in mind.

Broadcasting

A spacecraft is inherently a broadcast device. It transmits from on high, and many users can hear it at the same time.

To optimize the available downlink time, we are recommending the use of a broadcast protocol. This protocol adds information to each data packet to permit many stations to make simultaneous use of a single file download session. When one station in Maryland requests the current orbital element sets, there is no need for stations in Toronto and Miami to do the same, they should be able to make use of the information as it is downlinked to Maryland if they are all in view of the satellite at the same time. To make use of a broadcasted frame of data, each frame must be tagged with the file it belongs to and the position within that file that the data belongs in.

There should also be enough information for a station to determine if it has all of the data belonging to a file, and if not, to request that just the missing parts of the file be retransmitted. The specification titled "PACSAT Broadcast Protocol" describes a method of providing this additional information.

With a broadcast protocol, a groundstation can simply monitor the downlink and accumulate files of data. Since files

gathered in this way will have been unsolicited, the format of the contents may not be known to the user. For example, if one asked for a file of NASA format orbital elements, one can make a good guess that the resulting file contains NASA format orbital elements. However, if a "random" file is captured, its contents may not be understandable simply from inspection. Some additional information, such as a file name, data type, description, creation date, etc., may be required. Each broadcasted file, therefore, needs a header in a standard format with this information. The specification titled "PACSAT File Header Definition" describes a method of providing this information.

We hope that the broadcast protocol will maximize the use of the downlink. It should reduce the number of requests for files of general interest. It should also reduce the uplink load, since a broadcasted file does not receive an ack for each frame or group of frames. In the best case, only one "ack" is sent for an entire file, and that would be the request to stop broadcasting it.

File Server

As a data transfer and storage device, a PACSAT can serve a multitude of purposes. It can store telemetry, digitized voice and video images, personal mail, forwarded mail, or anything else that can be stored in a computer file. Mail forwarding is a good example of an excellent use of a PACSAT. AO-16's 1200 baud link could easily be used to transfer 240k bytes of uncompressed forwarded mail in each direction between California and England in 24 hours, with just one morning and evening pass over each location. UO-14's 9600 baud link could move 1.6 Mb of data in the same time. A PACSAT can store up to 8Mb of data. This would make a powerful addition to the current HF relay network.

The problem, however, is that the current amateur network is in a state of flux. New addressing schemes are proposed every few weeks, new routes and new ways of routing are proposed, tried, discarded or modified. This is good. Implementing the software on a spacecraft to follow these shifting designs is difficult, however. The testing required for the spacecraft is more rigorous, especially on the microsats, where the same computer is used for the BBS and to keep the batteries charged. Faulty forwarding code could crash the computer, which could cause damage to the batteries or reduce their life expectancy.

The amount of program memory is limited on the spacecraft as well. To counter the effects of high energy particles above the earth's atmosphere which cause memory bits to be changed, the PACSATs use 12 bits to store 8 bits of program data. The extra bits are used to correct for single bit errors. To keep the cost down, and to reduce the power used (AO-16's CPU uses about 500 milliwatts, on average), only 256k bytes of program space is available.

We have a desire, then, to keep the spacecraft code simple and stable, while still allowing it to be a useful part of the changing amateur network.

We propose that the spacecraft be primarily used as a file server, moving data files from one point to another. The

These are the current versions of the PACSAT protocols as of 08May90. An addition specification, the low level file transfer protocol, will be available shortly.

DATASPEC.STP

Definition of the definitions. Draft 5.

BROADCAST.STP

The broadcast protocol. Draft 8.

FHEAD.STP

The standard file header. Draft 6.

PACSAT would have no knowledge of the contents of the files, nor would it take an active role in the forwarding of mail messages. Groundbased software could, however, make the PACSAT system look like a familiar BBS to the user, and it could intelligently forward mail.

A PACSAT will know how to receive and transmit a standard file format. All files will have a standard header, the same one that is used by the broadcast protocol. It will also know how to select files for transmission based on the contents of the header. This feature can then be used by groundstation software to emulate any desired user interface.

For example, assume that a user wanted to send a personal mail message to a friend. In the current terrestrial environment, he would connect to a BBS, which would lead him in a question and answer session something like this:

<u>Remote Computer</u>	<u>User</u>
What do you want?	Send message
To whom?	Fred
Title?	Club meeting
Message?	Meeting at 8 p.m.
What do you want?	Read new mail.
Message #200....	

Using the PACSAT system, exactly the same exchange would take place, except that the conversation is between the user and his local computer. The message is stored for later transmission to a PACSAT. The read new mail request is also stored. The next time the PACSAT comes overhead, the computer does the following:

- Builds a file with a standard PACSAT header. The header says that the file contains a mail message, from you, to Fred.
- The file is compressed, and sent to PACSAT.
- The local computer then sends a message to PACSAT that says: "send the next file who's header meets the following criteria: it's a mail message type, the destination is me, and the file number is bigger than x."

"x" is the number of the last file received on the ground, and is kept by the local computer. After the pass, the local computer can now print any new mail received. To the user, it looked pretty much the same.

What about file forwarding? A forwarding gateway would need to know what type of mail it could forward. Let's assume that the routing scheme of the week is based on a hierarchical string containing states, like nk6k.ca.usa, and this gateway handles mail to CA, NV, and OR. The gateway would send a message to PACSAT containing the following request:

"Send the next file who's header meets the following criteria: it's a forwarded message, and the destination string contains '?ca.?' or '?nv.?' or '?or.?', and the download count is 0."

The file would be received, decompressed, and imported into the standard BBS program after the pass.

In this way, the ground program can be as simple or as complex as required, the PACSAT only needs to know how to select a file for transmission based on the contents of field in the standard file header.

Summary

These two ideas, broadcasting and file server, are certainly different from the current common usage of packet radio on the amateur bands. We feel that this is the best approach for the special case of a PACSAT, however, and that with suitable groundstation software, these concepts can be integrated into the mainstream. A prototype of the broadcast file transfer method has already been implemented by one of us, Jeff Ward, and is currently being tested on UO-14. There is still much implementation work to be done.

Comments on this paper and on the referenced specifications are solicited. Address comments to:

Telemail: HPRICE or UOSAT

Compuserve: 71635,1174

Packet: NK6K @ WB6YMH.#SOCAL.CA.USA.NA

EOT

Building a "Real" Network

Continued from page 8

UNIX system will make new applications easier and faster to construct.

Actually "doing it"

In the south bay area several of us are going to begin construction of the aforementioned network. Currently we are planning on between three and five nodes interconnected using full-duplex links on 6M, 1.25 M, 70 cm, and perhaps 33 cm and 23 cm. User access to the network will be on 2M as it is now. Each area will have its own 2M frequency

There will be at least two battery-backed UNIX systems to provide services to the users. The UNIX systems will also provide the name server function so that end users will not need to know the addresses of all the other users in the network. This network will also have a gateway to the standard BBS network and may have a gateway to the Internet if we can solve the problem of preventing non-ham access to the amateur packet network.

As time goes by the RF links will be upgraded from 1200 bps to 9.6 Kbps, 56

Kbps, and higher, as the RF hardware becomes available. The full-duplex point-to-point links should support a very large number of users with very few retries. The nature of the network will prevent the congestive collapse that is typical of current amateur packet radio networks.

I hope that this article spurs your interest. We are looking for other hams who are interested in assisting us and participating in the new network. If you have questions or comments please address them to wb6rq@k3mc (BBS), to wb6rq@ a.wb6rq.n.ampr.org (SMTP/TCP/IP), or to brian@teletbit.com (Internet/uucp).

EOT

Walking Mobile Packet Radio Station Around The Earth

Fred Moore, KG6HQ
Walking Rainbow Earthpilgrim
784 Rosewood Drive
Palo Alto, CA 94303
tel. 415-327-1104

[Editor's note: Fred is one of those free spirits that actually practices what he preaches; he represents, I think, a little part of us all. And he is not some far-out weirdo: Fred founded the Homebrew Computer Club! See the book "Hackers" by Steven Levy. We hope you enjoy Fred's short article.]

I have been walking south from Vancouver since August 31, 1989, and crossed the Golden Gate into San Francisco on Earth Day. This walk, which I call the "Walking Rainbow," is a long term non-commercial project to promote respect for the earth by living simply in harmony with nature. Less is best.

Combining high tech and low tech, I have designed and built two lightweight "tension-structure" carts to carry my camping equipment and supplies. (I don't need two carts, but bring them both so that other walkers who join will have use of a cart. Each cart can carry 300 lbs or more.) I am testing out a portable single-pot wood-burning cook stove of my design which is fuel efficient because the air is pre-heated before entering the combustion chamber. I also have plans for building a portable solar oven, a portable yurt, power assist motor for going up hills, corn grinding brake for slowing downhill, and other appropriate tools for nomadic living.

While in the S.F. Bay Area for a couple of weeks, I plan to equip the carts with 12 volt photo-voltaic modules to power a portable computer and packet radio gear.

The computer would be used to write and publish articles about my designs, prepare graphics and technical drawings, simulate and model the physics of these

designs to optimize them, keep a diary for an eventual book about the walk, play with cellular automata programs for enjoyment and insights into how natural systems might work, maintain and address list of contacts, and be the terminal for packet radio communications via the Microsats while I am walking in foreign countries. So I am looking for a portable computer workstation that can be used in the field, such as an AGILIS System. I welcome help in locating sponsors for this project. Advice and technical assistance are also needed.

[Editor's note: I know that Fred is Most Interested in finding a way to get an inexpensive Macintosh Portable to take with him; any helpers out there?]

The walk route will take me down the coast to Los Angeles, east through Arizona, New Mexico, Texas, and south from there (Mexico, Central America, South America, etc.). I'll be checking in to the packet frequencies on 2 meters and 70 cm along the way and would be delighted to meet hams interested in this venture. Perhaps a few amateurs would be willing to act as base stations and gateways to various computer nets for the reports I'll be sending back when I'm south of the border. It is going to take some advance work to get permission to operate packet in other countries and I need to begin that process now. Any suggestions of contacts in Mexico or Central America who could assist in this process would be greatly appreciated. Thank you.

Walking for a green earth
Pushing colorful carts
15 miles a day on average
With rainbow banners
And Earth Flag flying.
Heading south to meet people—
Listening, learning, respecting all.
Discovering in our diversity
A balance—harmony with nature.

On a search for how to live simply
Within a nomadic community.
Combining high-tech and low-tech
In the design of appropriate tools
For living lightly on the earth:
Carts, bikes, portable yurts,
Single-pot cook stoves, solar ovens,
Photo-voltaic modules for powering
A portable computer and
Satellite communication equipment.

Can we find a sustainable economy
That values the web of life,
That sees ourselves as part of nature,
That no longer treats the earth
As a commodity?

Walking is a meditation—
A time for reflecting
On what is important.
Walking puts us in touch
With our body,
With the Feminine,
With our being.
Walking reminds us
To stay humble
And to continue to give thanks
To the earth.

—Fred Moore

EOT

9600 Baud Packet Meeting Minutes

Minutes of the 9600 baud packet meeting held 6 July 90.

Ron Bardarson, N6VUW

Attendees

AA6IW, KG6HQ, KK6KR, N6TQS, N6VUW, N6XQF, N6YVB, WA6VJY, WB6QZL.

Interested Others: K3MC, KA6FUB, N6OIM, N6QMY, WB6GFJ, WD6CMU.

A short preamble on the advantages of 9600 baud packet, with a quick list of 7 possible FSK systems was followed by a short discussion on the need to generate more interest in 9600 baud. A general discussion followed, with these results:

Modulation Techniques

Three possible 9600 baud implementations were discussed: PSK, FAX, and FSK.

PSK is interesting because of possible satellite compatibility, but since hardware availability was unknown it was not further considered.

FAX is interesting as it runs in a 3 kHz bandwidth, experimental hardware exists (AA6IW) but there are concerns about every connect requiring training and possible long turn around time. FAX costs are not less than FSK costs and further development work is required before it can be 'plug-and-play'.

FSK is the oldest and best established technique, with numerous backbone systems already in place around the country. FSK is at the 'plug-and-play' level (getting to the varactor and discriminator is not that difficult, especially in older radios or Hamtronics units). FSK hardware in the form of G3RUH modems already exists at several QTHs in South Bay (with N6TQS and N6VUW placing orders as a result of the gathering). TAPR K9NG (probably packetRADIO) modems are compatible as they use the same scrambler algorithm. W2DUC/Hamtronics modems

need a retro-fit of scramblers/descramblers to be compatible.

WB6QZL had a Pac-Comm G3RUH modem tied in with a TNC-2 clone which was examined with a lot of interest.

A majority of the attending hams would employ the FSK 17-bit scrambler 9600 baud systems initiated by K9NG in 1985 (4th Networking Conference) available from TAPR or the compatible G3RUH modems available from G3RUH or Pac-Comm.

TAPR packetRADIOS are at least a year away from general availability, no one present was a beta site.

Bandplan

The NCXPN band plan's 9600 baud frequency is currently listed as 145.71, but QZL commented that this frequency has been shifted several times. Since 9600 baud systems are likely to be crystalized, changing frequencies is not trivial, cheap, or fast. In reading the NCPA DOWNLINK from Spring 90, I find that changing the band plan has occurred and the latest is that DXPSN (spotting network) may move to 145.71 MHz with N6VV assigned to task of communicating with all concerned parties (like US!).

QZL is crystalized for 145.73, and it may turn out that a possible 9600 baud BBS also is already on 5.73. Since there are 16 packet allocations on two meters but only one of them is for 9600 baud (a situation that will change), I suggest that we start on the frequency that most of the crystalized equipment exists on, 145.73 MHz and convince NCPA to change once more. 1200 baud users obviously have the flexibility to work their 15 channel allocations.

To obtain access to 5.73 we can either use the historical method or get official action from NCPA/NCXPN (i.e.

AA4RE, K6RAU & N6VV) if they are an FCC recognized frequency coordinator.

Other bands were considered, but two meters prevailed due to ease of access.

Unfortunately, the notice for a July 8th General Meeting of NCPA was distributed too late for my attendance. [Editor's note: there was no NCPA general meeting on July 8th.]

BBS

There are TWO potential offers of a BBS available to support 9600 baud packet. Details are currently under discussion, further blow-by-blow accounts may appear....but I'd probably just report the end result.

A BBS is a KEY requirement for a successful 9600 baud packet group. Multiple BBSs will help to improve the available frequency allocation situation.

Coordinator

I was selected to be the information exchanger, contact point, and part-time radio surgeon.

No formal organization is needed yet for this small group, all communication between members will occur via the existing 1200 baud network (for which we owe thanks). Future growth will require a more formal organization.

As an RF staff engineer, I have access to equipment to support varactor and discriminator mods. The 'group' will act to assist others to get 9600 baud up and running throughout SF Bay at the user level, a chance for NorCal to be first again in the packet community.

Next meeting

To Be Announced at a Later Date, watch for it.

73 and no retries
N6VUW@N6IIU.#NOCAL.CA.USA

NCPA (NCXPN) H&W Traffic Committee

Minutes for Meeting, June 9th, 1991

Walter Borlase, N6LDL

The meeting convened at the Los Gatos - Monte Sereno Red Cross Building at 1:00pm.

Attendees

Steve, KA6ETB, NTS Packet
Dave, N6JQJ, SEC Santa Clara V.
Roy, AA4RE, Programmer
Eleanor, KA6VEU Marin County OES
Bob, WA6VOI, Marin County OES
Roger, WB6HZO, Marin County OES
Steve, KB6HOH, Marin Co. RACES
Weo, WN6I, Santa Clara (ARES Data)
Sharon, N6MWD, ADEC Santa Clara
George, WA6YYM, DEC Santa Clara Co.
Russ, NW6U, Santa Cruz RACES
Frank, N6FW, West Ops HQ ARC
Gene, N6ANE
David, AA6RM, EC San Francisco
Jim, KA6IVF, EC Central CCC
Jim, N6PWX, Contra Costa Co.
George, KI6YK, SYSOP & EC CCC
John, W6VOM, NTS-ALCO RACES
Doc, W6ZRJ, HVP ARRL
Bob, KB6FEC, ARES, AEC SV
Scott, KB6UOO, ADEC Santa Clara
Gordon, KC6JAE, NALCO / West CC
ARES
Jim, K6APW, NTS - NALCO
Walter, N6LDL, Sr.AEC Los Gatos
/SYSOP

Objectives

1. Define the expectations of ARES/RACES, and their user agencies, of the NCPA AX.25 Bulletin Board System in processing Health and Welfare traffic in an emergency.

2. Submit recommendations to the NCPA (NCXPN) board.

NCXPN Packet System

Walter, N6LDL, opened the meeting with a brief presentation on the NCXPN BBS system. Emphasis was on forwarding capability and the current lack of a defined priority standard. All mail is, for the most part, treated equally. A handout was made available for all attendees.

EOC-EOC BBS System

Weo, WN6I, discussed the EOC-EOC BBS system planned for Santa Clara based on the multi-connect REBBS software. While the emphasis is expected to be on tactical traffic, Weo did indicate that there was some expectation that limited H&W Traffic could be expected as well. How traffic would be handled beyond the EOC-EOC BBS system was not yet an issue. While hooks into the NCPA system are possible (it uses standard REBBS protocols) there are none currently planned.

ARES Database

Weo then went on to the ARES Database system. This multi-connect on-line packet system allows the user to define a limited database file (five fields available) to keep track of volunteers, victims, etc. It's use in emergencies is yet to be established as there is some concern about having names transmitted over an open channel that could be monitored by others. It is for that reason that the Red Cross, for example, is not likely to use the database for keeping track of shelter victims. Thus it is not likely that having an automated request program against the database would be useful unless an agency wanted to use it to keep track of volunteers, for example. The ARES Database has some limited BBS capability, but its primary application is as a packet database.

NTS System

Doc, W6ZRJ and Steve, KA6ETB confirmed that packet is not a 'sanctioned' ARRL NTS medium for moving the mail. While a fair amount of traffic is moved on packet, there is always ongoing concern that packet is an open loop system. That is, the unattended automated forwarding capability is seen as a mixed blessing. The mail can move through the system without any human intervention, but it can just as easily get stuck on a board without an NTS operator, and is thus subject to the 'interest' of the sysop or traffic designee. Other dilemmas are crashed hard disks, ill kept systems or forwarding stations, etc. In the 'normal' NTS system there is supposed to be a live human to take the

handoff between voice, CW, RTTY/AMTOR nets to reduce (you can never eliminate) the chance for lost or unhandled mail. Until such time as there is a responsible NTS Packet Manager in every BBS system the decision of ARRL Management is likely to remain unchanged.

A significant majority felt that incoming traffic should be 'rejected back' to the incoming gateways...

One point brought up in the meeting was the use of ARL codes versus plain text in NTS traffic. While general consensus was not requested, it was understood that using these codes for international traffic was causing traffic to go undelivered in some of the Americas, Australia, etc. Walter, N6LDL did point out that several messages from sysops around the world asked that plain language be used throughout. In fact, in some cases the ARRL codes were causing political problems for foreign sysops as their bureaucrats can, and have, taken the codes to be secret messages to third parties.

RECOMMENDED ACTION: Use only plain text in packet NTS messages.

Red Cross

Speaking on behalf of the Red Cross Frank, N6FW, said that they were not prepared to support incoming H&W traffic for at least 72 hours (except requests via MARS). While the ARC feels the focus should be on outgoing H&W traffic, they are not prepared to set up a formal structure with amateur radio until we can guarantee delivery within 3-days, as is currently the case for the U.S. Postal Service. Frank did say that outgoing traffic could be voluntarily handled by the hams by setting up tables in shelters and taking messages from victims for transmittal to loved ones. The use of ham radio for reporting the status of victims in shelters, however, was not likely to be

Continued on page 16

What Was the Question?

An alternative opinion on the report of the H&W Committee

Don Simon NI6A

Well, I kinda expected the results that occurred in the H&W Meeting for many reasons, not that I think that it is functional nor that it will help ham radio or victims any.

The first reason it failed is that one almost never gets anywhere asking ECs what they want to do with H&W traffic. They all have much more serious business to take care of and most are short handed. Most ECs also never check into NTS nets (a few very rare exceptions) and most are a bit intimidated by NTS format and feel thus either defensive/aggressive or at least shy in an NTS structure. As you know, an EC has to try to find operators to man operations 24 hours/day during disasters and top coordinate with many agencies, and to train their manpower. To take pride in what they are supposed to do almost requires a fulltime job. This I have learned being assistant EC to 3 different ECs and working closely with many ECs throughout Northern Calif but mostly Contra Costa and Alameda Counties.

Of course there have been a few exceptions. The old NAPA EC, N6XN, used to be an NTS op and we actually handled over 300 welfare messages during the NAPA fire in 1983 through a combined effort of NAPA ARES and NTS. WB6UGG, Barry, the CDF coordinator and former DEC for South SCV Section, was also very supportive, but these are exceptions. Thus, if you ask the question from ECs and from agencies, they almost always agree that they are over-worked already and do not want to deal with it, it's just an extra burden. During a disaster they are mostly burned out and like chickens with their heads cut off. This is not to depreciate their fine efforts in the field of emergency communications (versus welfare). Of course this doesn't mean that it can't be done.

Now, if the task of the H&W Committee was defined as how can we provide the H&W service for loved ones via amateur radio and, in particular, amateur packet radio, how could we improve on what we did (and a lot of what we did was done very well at least in SFD and East Bay and I am sure there also), then I think

we could have gotten somewhere. In other words, if we ask the wrong question: "What do ECs want?", we would get the answer that we got. ECs are not NTS or Welfare oriented. There is a small statement in EC, SEC, and DEC job descriptions about Welfare and NTS interface, but it is purposely vague. (A point of contention with the ARRL and myself for many years.)

...to ask for an automatic moratorium, whether or not we can handle welfare traffic, is more than self defeating...

So, what could we do to get the job done despite the ECs, despite ARES, despite, ARRL, and, yes, despite many in NTS leadership itself. If we had asked this question, I think that many software, hardware, and organizational answers, or at least possibilities, would have occurred. If we look at the 1989 Earthquake Welfare effort it wasn't so bad considering there was no grand plan existing. So we SHOULD ask: What could we do to improve that? How could planning help? Can better software and procedures be established nationwide to get the job done? I, of course, think the answer is: Yes. If packet proved that it could move thousands of messages even with no plans, just think what could have been done with some intelligent forethought!

The tragedy (in my opinion) is that NTS exists on a daily basis to provide message services and message handling training, but almost every time during a disaster when the chips are down and the commercial systems fail, NTS fails to mobilize despite the fact that the physical RF links are there. But normal NTS nets are limited to not more than 200 messages per area per day. It breaks down during a large fair, special event or disaster. Packet however lends itself exceptionally well to the task. High bulk traffic could be moved nationally in and out of the disaster area as a COMMUNICATIONS SYSTEM FOR THE PUBLIC. Wow! What a good human use of amateur radio! What a great service to victims and their families when long distance lines are down for days and some-

times for over a week! What great public relations for amateur radio! Who could be against it?

Ignorance is against it. Over-worked ECs who think that NTS is in competition with ARES, or NTS ops who think that ARES is in competition with NTS, or NTS guys who may think that packet is in competition with NTS, etc. These guys, fortunately, are not in the majority, but they are established in various circles which were well represented at the H&W committee meeting.

The actual proposal of the question, in other words, was: What does ARES want? What does Red Cross want? What does NTS want? These questions would bring predictable and unopportunity results. If these were the questions the NCPA board wanted to answer, then they got predictable answers. As a long-time member of all 3 organizations, it was not surprising to me.

So to ask for an automatic moratorium, whether or not we can handle welfare traffic, is more than self defeating—it emasculates the system, makes it dysfunction and condemns it to irrelevance. It kills morale and wants us to take up golf or chess...hi.

Maybe experience will change some guys minds, maybe GENIE or CompuServe or other satellite-based communications systems will take over and leave amateur packet in the dust. Anyone is free to create a local delivery system. 99.9% of the inquiries will be for those who are actually unaffected but who have lost long distance commercial telephone service and can be reached through local exchanges. This number is from actual experience. To me, it is a valuable service if we can assure people that their close friends or relatives are safe in times of disaster when multiple casualties have occurred and long-distance telephone service is unoperative.

Yes, we could discourage inquiries. Certainly all inquirers should know that delivery is not guaranteed. The point is that people will try to communicate via any way possible to find out about their loved ones during a disaster. Certainly

Continued on page 17

NCPA (NCXPN) H&W Traffic Committee

Continued from page 14

ever sanctioned as every effort is made to protect the identity of the victims, and our bands are not secure. H&W Traffic at the request of the victims, however, is not so limited.

ARES/RACES

Dave, N6JQJ, Section Emergency Co-Ordinator for Santa Clara, made it clear that ARES/RACES resources were generally stretched to the limit in an extensive incident like the last earthquake. Accordingly he is taking the stand that he can support H&W traffic ONLY TO THE EXTENT REQUESTED BY THE SERVED AGENCIES. In short, unless the agency(ies) initiate it ARES/RACES isn't going to handle it (at least until the manpower is available to support 'general' NTS type H&W traffic). David, AA6RM, EC for San Francisco echoed the same sentiments.

The chair then asked the group to focus on issues and recommendations. The following summarizes the various statements offered. While some are repetitive to those expressed above, they are repeated here as they were re-emphasized at this time.

1. Packet should be used for repetitive and/or complex technically long messages. It should also be considered for traffic that would normally have been sent digitally (modem) but the normal path is not available (e.g. phone lines are down).

2. The Red Cross looks at packet in a transparent way. How we handle the traffic is left to us. They would use it for H&W traffic if we could give them strong assurances that any and all traffic accepted for delivery would be delivered within 3 days, as currently 'guaranteed' by the postal service.

3. ARES (Santa Clara) indicated that they are committed to support H&W traffic FOR SERVED AGENCIES ONLY (at least to start). So incoming NTS traffic does pose a problem, at least short term. Further, if the bbs system is tied up with incoming traffic that cannot be effectively handled (because the same people are being committed to voice

nets), then it won't be of much use for other emergency traffic.

4. Roy, AA4RE, rose to point 3. by suggesting the programmers could write code that would allow the sysop to put the BBS into an emergency mode that would have one or more of the following attributes:

a. Restrict access to those authorized by SYSOP.

b. Reject incoming bulletins, NTS and personal traffic unless it carried an agreed code (like "Z") that only could be authorized by a sysop, or designee. This is seen mostly as a gateway function as the bbs would have to send back a reject message based on the fact the bbs is in the emergency mode with restricted access. Limited access and restricting messages to those coded with, say, SZ would complete local control.

c. Advise all SYSOPS that BBS's in the emergency mode will reject all traffic save that carrying the agreed code. Further, only Red Cross, MARS H&W, or other 'authorized agency' originated traffic should be allowed to carry the emergency designator. John Doe's emergency traffic will have to wait until the bbs system in the affected area has been returned to normal use. In short, the SYSOP controls traffic TO the affected area too.

d. As noted in a. & b., outgoing bulletins (about the emergency), and NTS traffic would be processed, subject to the restricted access limitation. Personal mail would be blocked as would general bulletins. One option to restricted access might be to allow open connects but entry restricted to NTS traffic, and bulletins only by 'authorized' connects, etc.

There was general agreement in support of the emergency mode capability, and restricted access to the BBS. Not clarified was whether limited access was total, or as described in (d.) above.

Roy also indicated that code could be included to allow the SEC to initiate the emergency mode, but Dave, N6JQJ, felt that should be a sysop function. While he is prepared to ask the sysop to switch to the emergency mode, he felt that local conditions might well dictate the appropriate response too.

5. A significant majority felt that incoming traffic should be 'rejected back' to the incoming gateways, except as authorized under Roy's suggestion, until the bbs can be returned to 'normal use'. However, outgoing H&W traffic should be encouraged.

6. Does NCPA need an Emergency Coordinator??? The point was raised, but no consensus reached. (Chair: Maybe each SYSOP needs to consider their role as a potential emergency bbs in their city and/or county.)

7. Several attendees suggested ARL codes be dropped for emergency (and normal) NTS type packet traffic. (See NTS recommendation above.)

All attendees are invited to comment on the minutes which will be submitted to the board in early July. As the board requested recommendations primarily of ARES/RACES representatives, it is clear that we should recommend the hold on traffic, the initiating of an emergency mode capability, and 'limited' access to the bbs system. This must further be rationalized with another committee formed to explore the use of the BBS system for handling tactical traffic in an emergency.

Corrections to the minutes must be submitted by June 30th to be assured they are incorporated or appended. Comments by others, and submitted by June 30th, will be passed on as an Appendix. Such comments (minutes or general) should be sent as a bulletin SB H&W @ ALLCAN.

IF YOU DISAGREE WITH THE RECOMMENDATIONS CONTACT YOUR SEC/DEC/EC WITH YOUR ARGUMENTS AND SEEK RECONSIDERATION THERE.

Respectfully submitted,

Walter, N6LDL @ N6LDL

EOT

SAREX, 144.95, DXPSN, BBSs, and Keyboarding

Mike Chepponis K3MC

The upcoming SAREX mission (recently postponed due to hydrogen leak) will be using the frequency 145.550 as a packet downlink from space, with three uplinks:

- 144.950 (Primary frequency)
- 144.910
- 144.970

The primary frequency is -600 kHz from the shuttle downlink freq, so we can use the -600 kHz offset on our radios. (Actually, if one has a separate rx and tx, full duplex can be used, but that is a different matter.)

NCPA has 144.950 allocated for DXPSN. I have been in contact with Tom Wood, N6IXX (the DXPSN Liaison to NCPA) about this, and have received from Jay O'Brien, W6GO, his thoughts on the subject.

144.95 is the home for six Packet-Cluster nodes, as well as one backup

node. In addition, five NetRom nodes support the PacketCluster system on that frequency. Getting these nodes and the hundreds of users of this system to QRX for the 10-minute passes during the 10-day STS-35 mission seems like an impossible task! But Tom and Jay have agreed that if NCPA can find a temporary frequency for the DXPSN operation on 144.95 during the SAREX mission, then they would work to temporarily move all of the PacketCluster nodes and associated NetRom nodes, even though this may require new crystals for some of the rigs. The NCPA Frequency Coordinator is working on finding such a frequency, and we applaud the spirit of cooperation that Tom and Jay exemplify as part of DXPSN and NCPA!

But, even if we accomplish this temporary QSY, all is not peaches and cream. If Tony England, WA4SIR (the ham aboard the STS-35 mission) finds too much QRM on 144.95, he will listen on the other two frequencies. Since 144.910 is a keyboard channel, we

hereby request that all keyboard users be aware that the 144.91 frequency may be used during SAREX passes, and to try to QRT during those passes.

144.97 is a BBS channel; again, we request that the BBSs on that channel QRT during the time of the shuttle pass, or risk QRming the shuttle.

The good part is that the shuttle will be in a low-inclination orbit. This means that, for the duration of the 10-day mission, there may be perhaps three passes, and these passes will all be in the evening, and will be at most 10 minutes long and be spaced at approximately 90-minute intervals. Therefore, disruption to normal packet operations should be minimal.

Jay is working with W3XO and the ARRL to ensure that future SAREX missions do not use frequencies that are in such widespread terrestrial use.

So, thanks everybody for helping us all cut through this Gordian knot!

73 de Mike K3MC

EOT

What Was the Question?

Continued from page 15

some of the inquiries are not always from close friends or relatives, but that doesn't mean that the others are somehow less valuable. WE will not be able to prevent people from trying. If it is stopped on packet, they will try on SSB or GENIE or CompuServe or... My point all the time has been that amateur radio is a national communications service as defined by the FCC and that it may be able to play a functional role in this public service (as it often claims to do).

The solutions here remain fairly much unaltered. The problem is basically one of communication, education, and organization. It will require a lot of work.

...maybe GENIE or Compu-Serve or other satellite-based communications systems will take over and leave amateur packet in the dust.

Regarding the Red Cross, they have been looking for a way out for years. Basically, they are over-loaded with more basic inadequacies and similarly do not want to "bother" with the service. I think that some sort of national disaster message service may eventually emerge, independent of Red Cross, perhaps a merger of GENIE and packet, by public-minded computer buffs who understand databases and data communications and are dedicated to getting the job done regardless of the methods. WN6I is

working on a H&W version of the ARES DATA that will act as a server for AA4RE BBS. I think that in the future, there will be a much better solution using computers than what has ever been possible in the past using Red Cross TWIX systems or CW. The fact that there is no nationally dedicated amateur radio organization in existence today that is tasking itself with this project is disturbing, yes, but at the same time maybe that this will be some basis of a new and more relevant national amateur functional and human-orientated organization.

73, Don

EOT

Imagine that Cray Computer decides to make a personal computer. It has a 150 MHz processor, 200 megabytes of RAM, 1500 megabytes of disk storage, a screen resolution of 4096 x 4096 pixels, relies entirely on voice recognition for input, fits in your shirt pocket and costs \$300. What's the first question that the computer community asks?

"Is it PC-compatible?"

NCPA Board Meeting Minutes

Minutes of NCPA Board Meeting May 6, 1990

The Board of Directors meeting of the Northern California Packet Society (NCPA) convened at 1000 PST on May 6, 1990. Present at the meeting were the following individuals:

WA8DZP WD6CMU WB9LOZ K3MC
KA6ETB N6RAL N6QMY

All board members except WA6ERB WA6JCW were in attendance. The board members are:

WD6CMU WA8DZP WB9LOZ WA6JCW
N6RAL N6QMY KA6ETB WA6ERB

Board Actions

Old Business

1. WA8DZP reported that there are a total of 170 members as of the board meeting.

2. WD6CMU reported that the current balance is \$841.85. We have received a letter from Bank of America requesting our taxpayer ID number.

3. No response has yet been received to our letter to the DXPSN asking them to send a representative to the board meetings. WA8DZP will send another letter via registered mail to see if they respond.

4. K3MC attended the recent NARCC meeting as NCPA's representative. AA4RE continues to serve as NCPA Frequency Coordinator. He has sent a letter to NARCC concerning new 220 channels and asking for clarification on 900 MHz packet allocations.

New Business

1. N6RAL will invite KB6TKL, the NCXPN Director to attend future NCPA board meetings.

2. N6RAL was voted in as NCPA President. He previously was acting president. WD6CMU will remain as NCPA Secretary. N6RAL will contact WA6ERB to find out if he still intends to serve as a board member as he has missed the last two board meetings.

3. WA8DZP contacted the Pacifcon 90 committee as NCPA Liaison and volunteered speakers and a booth for this year's convention. He is to find out if WB9LOZ's plan of doing paid packet seminars at the Pacifcon site

will be allowed. DZP will report back to the board on the results on the upcoming Pacifcon planning meeting.

4. K3MC reported on the status of the NCPA newsletter. The second issue was hot off the press and was distributed at the board meeting. It went into the mail the general members on May 2nd. The board decided that the newsletter could print material from our sister organizations such as the NCXPN. The board also advised that any future articles which discuss the modification of radio equipment should include a suitable disclaimer. It was decided that enough money was available to produce at least one more newsletter. It is hoped that the new members which are raised from new memberships will expand the coffers enough to publish future issues as planned. The deadline for articles for the Summer 90 issue is May 15th.

5. The NCPA Pledge by W6MEO was referred to the NCXPN for comment.

6. K3MC reported on the NARCC meeting. There were no packet-related issues raised at the meeting. NARCC is not coordinating below 912 or 918 MHz due to the automatic vehicle locating primary allocation which is going into service in our area soon. This action matches that of the SoCal coordinating body.

Action Items

1. The next board meeting will be on July 8th at 1000 at a location to be announced.

2. N6QMY will contact an attorney for advice on how to handle the taxpayer ID problem with Bank of America.

3. N6RAL will obtain a copy of AA4RE's letter to NARCC and send a copy to the secretary.

4. N6RAL will contact WA6ERB to see if he wishes to remain on the board.

5. WA8DZP will find out if the Pacifcon will approve WB9LOZ's plan to hold paid packet seminars at Pacifcon. He will also act as NCPA Liaison to the Pacifcon 90 planning committee.

6. K3MC will investigate obtaining a bulk or 2nd class mailing permit for the newsletter.

7. N6RAL will refer the W6MEO NCPA Pledge to the NCXPN for comment.

EOT

NCPA Directors

Bob Bobrick, WA6ERB
WA6ERB @ KA6FUB

Eric Williams, WD6CMU
WD6CMU @ WD6CMU

Bob Sanders, WA6JCW
WA6JCW @ KD6XZ

Chris Marley, N6RAL
N6RAL @ N6IIU

Michael Bothe, KB6OWT
KB6OWT @ KB6OWT

Steve Harding, KA6ETB
KA6ETB @ N6LDL

Patrick Mulrooney, N6QMY
N6QMY @ N6QMY

Dewayne Hendricks, WA8DZP
WA8DZP @ K3MC

Larry Kenny, WB9LOZ
WB9LOZ @ W6PW

NCPA Officers

President:

Chris Marley, N6RAL
N6RAL @ N6IIU

Vice-President:

Eric Williams, WD6CMU
WD6CMU @ WD6CMU

Secretary:

Dewayne Hendricks, WA8DZP
WA8DZP @ K3MC

Treasurer:

Eric Williams, WD6CMU
WD6CMU @ WD6CMU

Newsletter Editor:

Mike Chepponis, K3MC
K3MC @ K3MC

Frequency Coordinator:

Roy Engehausen, AA4RE
AA4RE @ AA4RE

A Mexican newspaper reports that bored Royal Air Force pilots stationed on the Falkland Islands have devised what they consider a marvelous new game. Noting that the local penguins are fascinated by airplanes, the pilots search out a beach where the birds are gathered and fly slowly along it at the water's edge. Perhaps ten thousand penguins turn their heads in unison, watching the planes go by, and when the pilots turn around and fly back, the birds turn their heads in the opposite direction, like spectators at a slow-motion tennis match. Then, the paper reports, "The pilots fly out to sea and directly to the penguin colony and overfly it. Heads go up, up, up, and ten thousand penguins fall over gently onto their backs".

—Audobon Society Magazine

Where to Find a BBS

KJ6FY-1	Benicia	144.93
WB6JJI	Tres Pinos	144.93
KA6LRR	Hayward	144.93
KI6YK	Danville	144.93
WD6CMU	Richmond	144.97
N6EEG	Berkeley	144.97
W6FGC-2	Twain Harte	144.97
KB6GOZ	Petaluma	144.97
N6LDL	Los Gatos	144.97
WB6MIF	Magalia	144.97
KI6WE	Pleasant Hill	144.97
KD6XZ-1	Sacramento	144.97, 441.50
AA4RE-1	Gilroy	144.99
KB6DUI	Boulder Creek	144.99
WW6L	Piedmont	144.99
N6MPW	Ben Lomond	144.99
N6OA	Lemoore	144.99
W6PW-3	San Francisco	144.99
WA6RDH	Dixon	145.01
KI6EH	Santa Cruz	145.07
N6IIU-1	Palo Alto	145.07
KE6LW-1	Yuba City	145.07
KG6XX-1	Carmichael	145.07, 441.50
W6CUS-1	Richmond	145.09
N6ECP	Redding	145.09
KB6IRS	Soquel	145.09
N6IYA-2	Felton	145.09
K3MC	Fremont	145.09
WA6NWE-1	North Highlands	145.09, 441.50
K6RAU-1	Merced	145.09
WA6YHJ-1	Livermore	145.09
KB5IC	San Jose	145.73
KA6JLT-2	Menlo Park	145.73
WO6Y	Fairfield	145.77
KA6FUB	Martinez	145.79
WB6ODZ-1	Lake Isabella	145.79
KB6OWT-1	Sunnyvale	145.79
N6QMY-1	Fremont	145.79
N6REB-2	Modesto	145.79

The Band Plan

144MHz	
144.91	keyboard-to-keyboard
144.93	LAN ¹
144.95	DX Spotting Network
144.97	LAN
144.99	LAN
145.01	keyboard-to-keyboard
145.03	keyboard-to-keyboard
145.05	keyboard-to-keyboard
145.07	LAN
145.09	LAN
145.71	9600 baud TAPR compatible
145.73	LAN
145.75	TCP/IP
145.77	DX Spotting Network ²
145.79	LAN
146.58	DX Spotting Network

220 MHz	
223.42	node uplink (SBAY)
223.52	node uplink (NBAY)
223.54	node uplink (EBAY)
223.56	keyboard-to-keyboard
223.58	node uplink ("Other")
223.60	node uplink (SACVAL)

430 MHz	
100KHz-wide channels	
433.05	TCP/IP
433.15	NET/ROM backbone
433.25	DXPSN backbone

20KHz-wide channels	
443.31	backbone
443.33	backbone
433.35	backbone
433.37	backbone
433.39	backbone
433.41	LAN interlink
433.43	digital experimental
433.45	digital experimental & backbone
433.47	NET/ROM interlink, keyboard
433.49	TCP/IP
441.50	all

¹ 144.93 is used by TCP/IP in the Sacramento area.

² WO6Y remains on 145.77 as DXPSN/BBS liason.

Sending International NTS Messages

Steve Harding KA6ETB

In a recent bulletin, VK4BBS presented some valid criticisms of the ARL numbered radiograms that NTS operators here in the United States use. It seems that those people who handle our formal message traffic outside of our borders have no idea what those funny ARL numbers mean.

So, when sending formal traffic to a country with which we have a third party agreement, it is advisable to include a definition with the message, or, better yet, spell it out in plain English. It'll increase the chances of the message being delivered on the other end.

Secondly, always include a telephone number for the addressee. Many stations, particularly in Australia, refuse to handle any traffic without it.

What is NCPA?

NCPA, the Northern California Packet Association, is an organization formed to foster the Digital Communications modes of Amateur Radio. So far, we have defined our goals as:

- Education
- Coordination

Education means making information available about various Digital modes, and this newsletter is but one part of that education process.

Coordination activities include frequency coordination (NCPA is recognized by NARCC as the official packet radio frequency coordinator) as well as coordinating people and their various uses of packet radio, be they DX Cluster, BBS, TCP/IP, keyboard-to-keyboard, NET/ROM, Traffic/NTS, Emergency uses of packet, or even experimenting with new frontiers of various digital modes.

We in NCPA believe that the next revolution in Ham Radio will come about in Digital Communications Technology, and in the beneficial coordination among all users of ham Digital Communications Technologies.

We invite you to join NCPA! Become part of the most dynamic group of packet folks in Northern California!

NCPA *Downlink*

Northern California Packet Association
6680B Alhambra Ave. Suite 111
Martinez, CA 94553

First Class Mail